

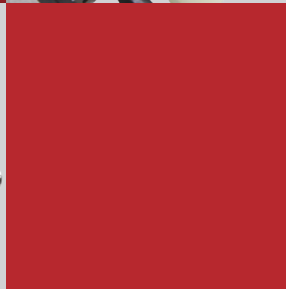

Hydraulic Shock Absorber Buffer

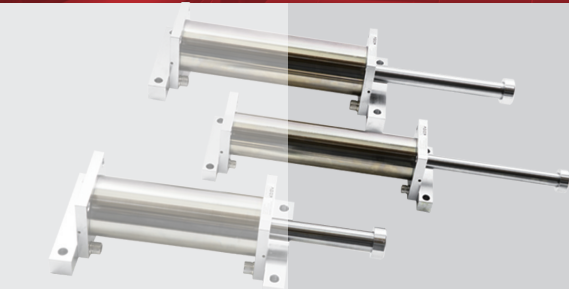

Softly
Safely
Smoothly

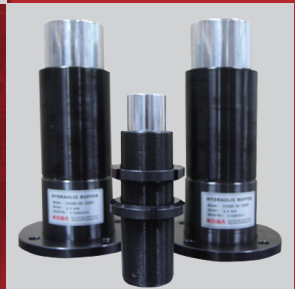

KOBA
Best Energy Absorption
www.kobapage.com

KRC Series

Rate Controls



KRC Series - adjustable speed controls

KRC is designed to control the speed of movement smoothly and safely in single and double acting with compression and tension, KRC has 12 step dial so you could adjust the movement speed in accordance with the condition of application.

Feature

- cycle rate : 60 cycle/h
- operation velocity up to 0,6 m/s
- temp range (-10~80℃)
Special (-30~100℃)
- Piston Rod : Hard Chrome(25_{um})
- Body Mount : Black Oxide or Ni Plated

KRC Series Ordering Information

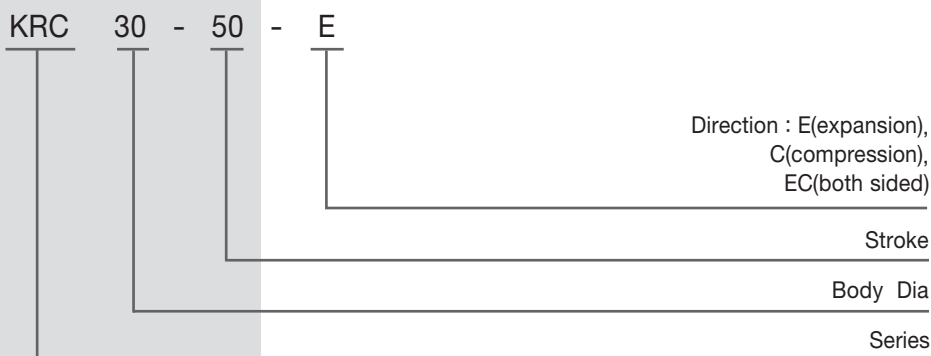

KRC 30 Series Engineering Data & Dimensions

Model	Stroke (mm) S	Max. Propelling Force (N)		Weight (g)	Dimensions (m/m)			Direction
		Ext	Comp		A	B	C	
KRC30-50	50	3,000	3,000	310	250	200	176	E,C,E&C
-100	100	3,000	2,600	380	350	250	226	E,C,E&C
-150	150	3,000	2,100	450	450	300	276	E,C,E&C
-200	200	3,000	1,400	530	550	350	326	E,C,E&C
-250	250	3,000	800	600	650	400	376	E,C,E&C

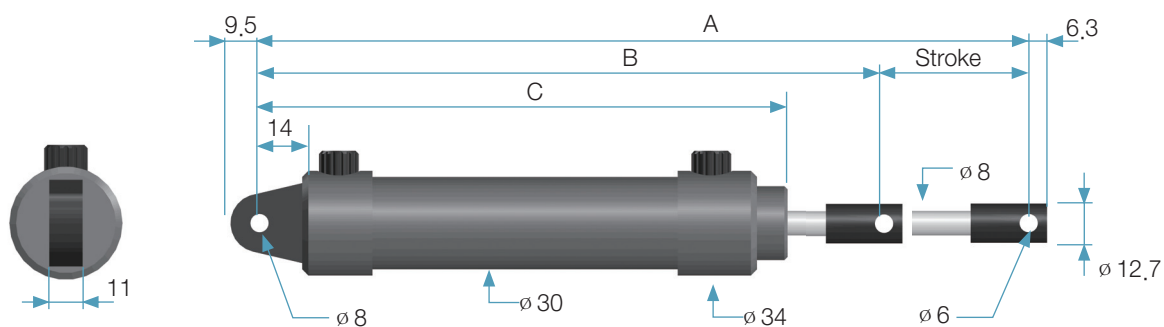

Adjustment Diagram

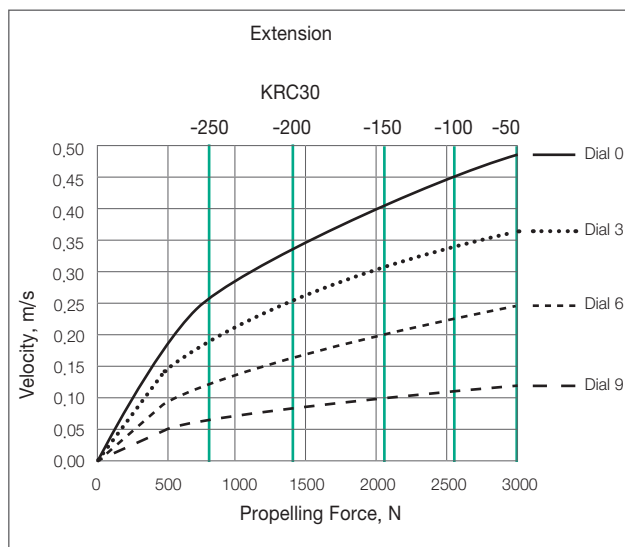
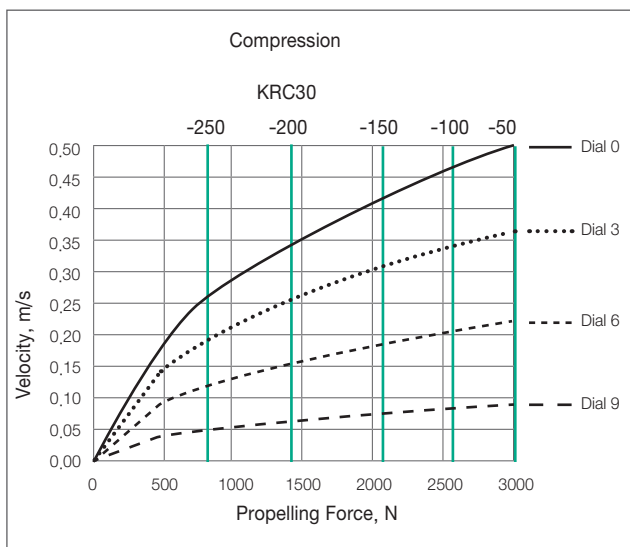

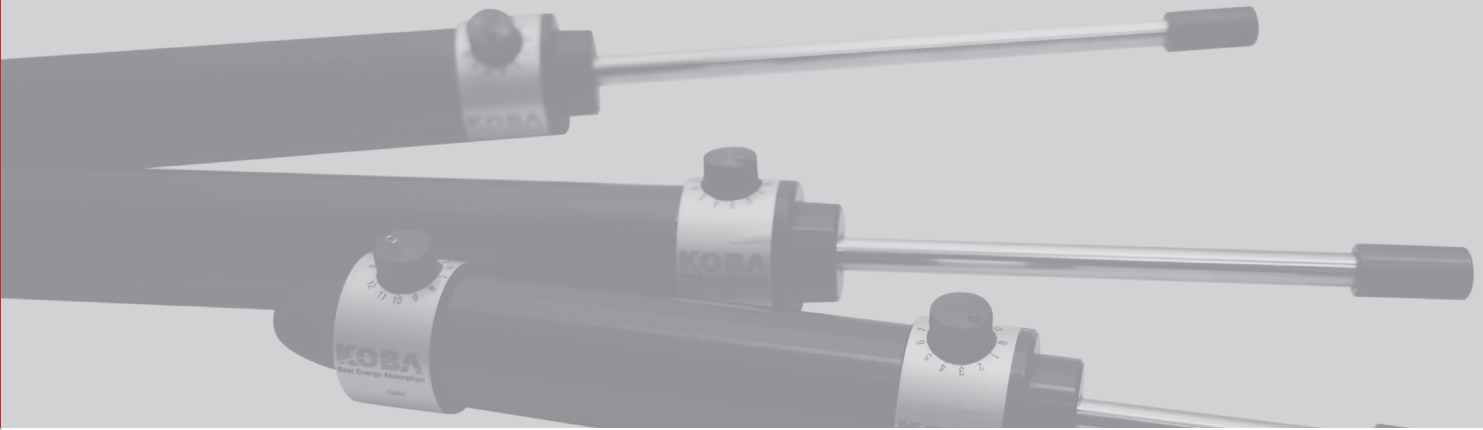

KRC 50 Series Engineering Data & Dimensions

Model	Stroke (mm) S	Max. Propelling Force (N)		Weight (g)	Dimensions (mm)			Direction
		Ext	Comp		A	B	C	
KRC50-50	50	11,000	11,000	2,000	250	200	175	E,C,E&C
-100	100	11,000	11,000	2,500	350	250	225	E,C,E&C
-150	150	11,000	11,000	3,000	450	300	275	E,C,E&C
-200	200	11,000	11,000	3,300	550	350	325	E,C,E&C
-250	250	11,000	11,000	3,600	650	400	375	E,C,E&C

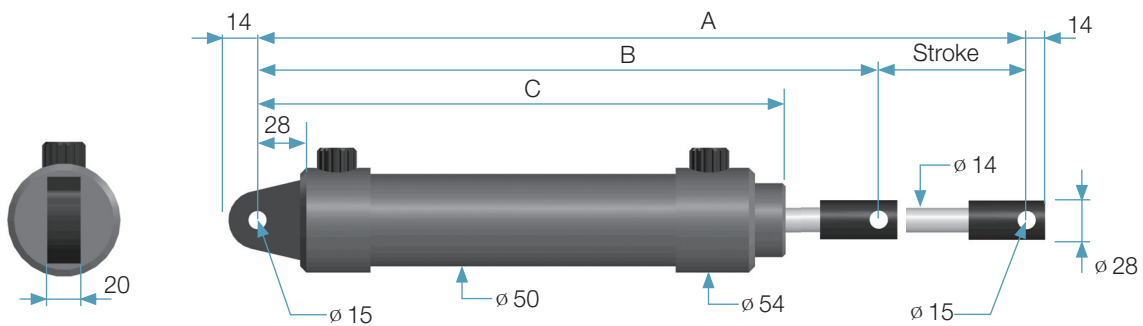

Adjustment Diagram

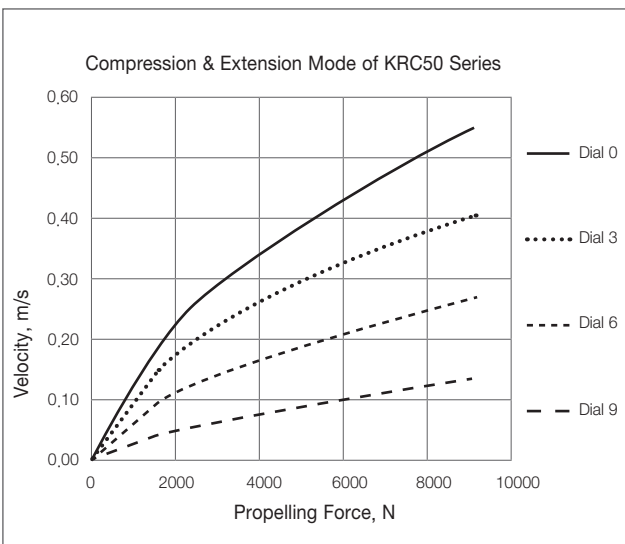

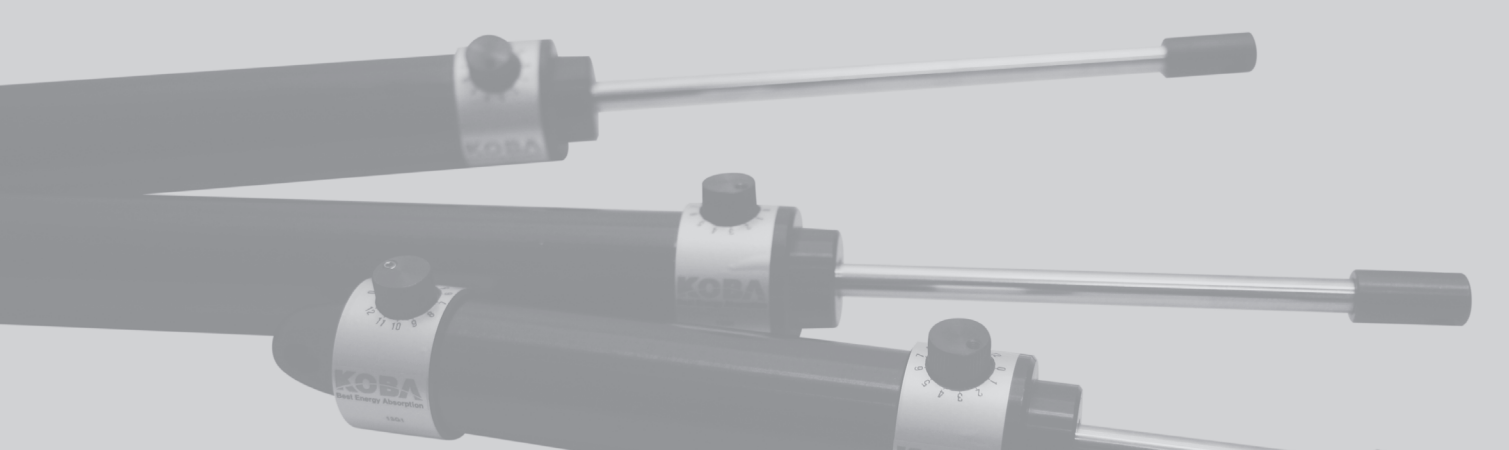

KRC 70 Series Engineering Data & Dimensions

Model	Stroke (mm) S	Max. Propelling Force (N)		Weight (g)	Dimensions (mm)		Direction
		Ext	Comp		A	B	
KRC70-50	50	20,500	20,500	1,700	237	180	E,C,E&C
-100	100	20,500	20,500	2,100	339	231	E,C,E&C
-150	150	20,500	20,500	2,400	441	282	E,C,E&C
-200	200	20,500	20,500	2,700	541	332	E,C,E&C
-250	250	20,500	20,500	3,000	643	383	E,C,E&C
-300	300	20,500	20,500	3,300	745	434	E,C,E&C
-350	350	20,500	20,500	3,700	847	485	E,C,E&C

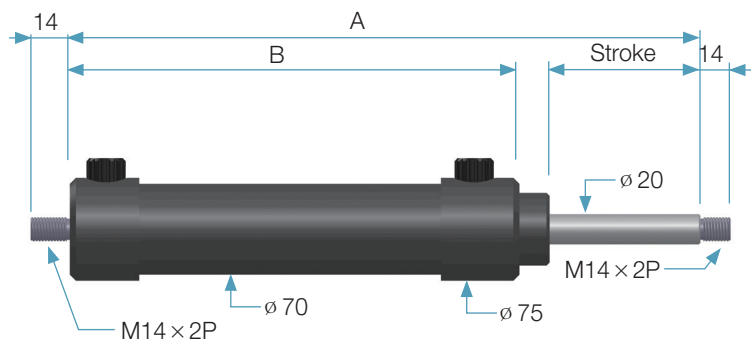

Adjustment Diagram

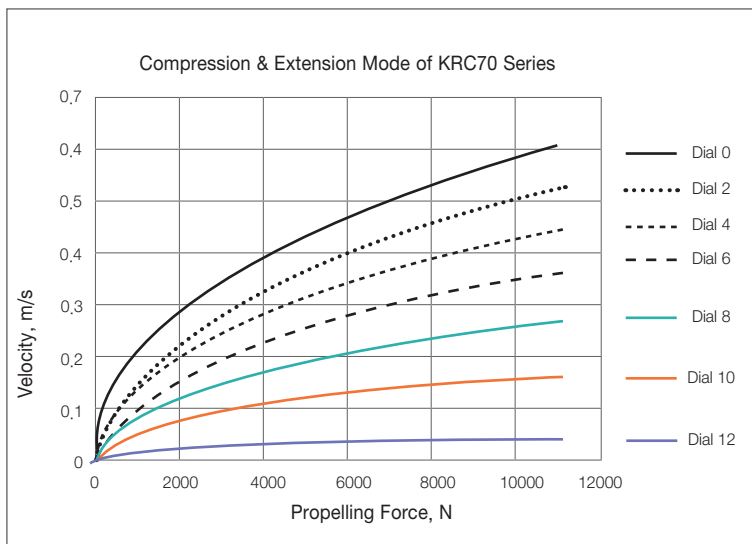

www.kobapage.com



KOBA
Best Energy Absorption



KOBA Co., Ltd.

12F, A BLOCK, KABELGREATVALLEY 32
DIGITALRO – 9GIL, GUMCHEON-GU, SEOUL, KOREA
Tel : +82-2-3397-7800 Fax : +82-2-3397-7811 E-mail : koba@koba.co.kr

Authorized Distributor



SAVANTEC AUTOMATION PRODUCTS

No.3&4, First Floor , Shop No.5, Mogappair Road,
Mannurpet, Padi, Chennai – 600050. Tamil Nadu, India.
Email ID : savantecap@gmail.com / info@savantecap.com
PH : 044-48568963 / +91 73583 12666
WEBSITE : www.savantecap.com

※The specifications in catalog are subject to change without notice in order to improve performance